

# Q-600/CF-600

Q-600 is an acoustic wall system of sandwich construction with an excellent sound reduction quality. Q-600 is a rigid system with integrated joint profiles and allows for easy and rapid installation. Flush surface with single seam joints. Available as a modular system. 50 mm panels available with vertical cable ducts in B-15. 70 mm panels have the possibility to draw cables horizontal and vertical.

## WEIGHT:

All weights are based on system weight, including all profiles.

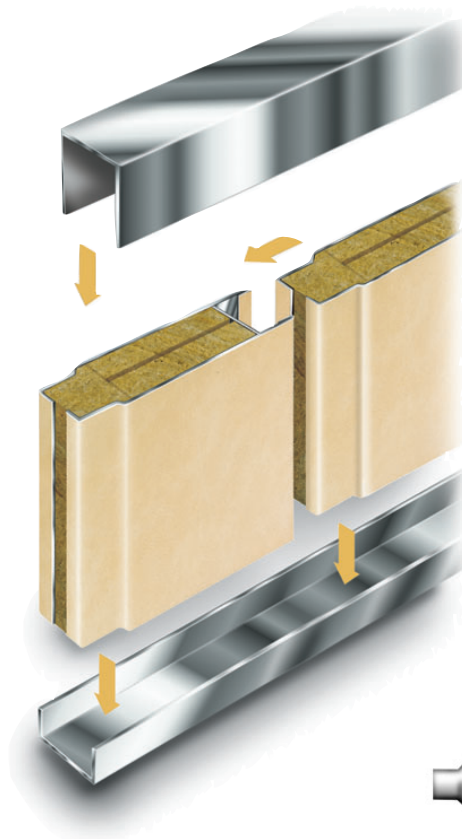

43-49 dB

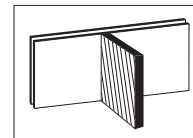

Partition only

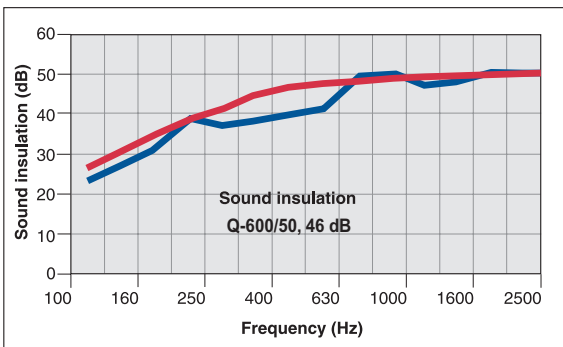

Adjusted References (red line) Sound Reduction Index (Laboratory measurement) (blue line)

DESCRIPTION	Q-600/50, 43 dB	Q-600/50, 46 dB	Q-600/70	CF-600/50	CF-600/70
Fire Class	B-15/B-30	B-15/B-30	B-15/B-30	B-15/B-30	B-15/B-30
Standard width	600 mm	600 mm	600 mm	600 mm	600 mm
Module length	up to 3000 mm	up to 3000 mm	up to 3000 mm	up to 3000 mm	up to 3000 mm
Module width	100-700 mm	100-700 mm	100-700 mm	100-700 mm	100-700 mm
Thickness	50 mm	50 mm	70 mm	50 mm	70 mm
Weight	19.8 kg/m <sup>2</sup>	21.4 kg/m <sup>2</sup>	19.9 kg/m <sup>2</sup>	25.8 kg/m <sup>2</sup>	26.2 kg/m <sup>2</sup>
Sound reduction	R <sub>W</sub> = 43 dB	R <sub>W</sub> = 46 dB	R <sub>W</sub> = 45 dB	R <sub>W</sub> = 47 dB	R <sub>W</sub> = 49 dB
Thermal Insulation	U = 0.64 W/m <sup>2</sup> K	U = 0.64 W/m <sup>2</sup> K	U = 0.62 W/m <sup>2</sup> K	U = 0.64 W/m <sup>2</sup> K	U = 0.62 W/m <sup>2</sup> K
Application	Partition	Partition	Partition	Partition	Partition



0575



MARINE INTERIOR SYSTEMS

WWW.NORAC.NO



# Q / CF-Walls CONNECTING DETAILS

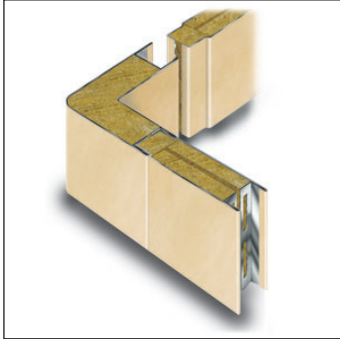

Rounded corners

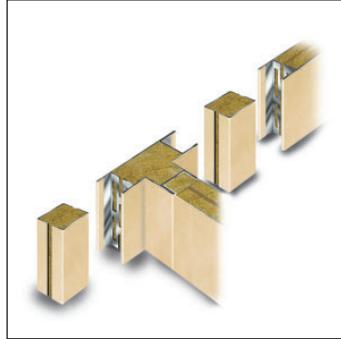

T-element

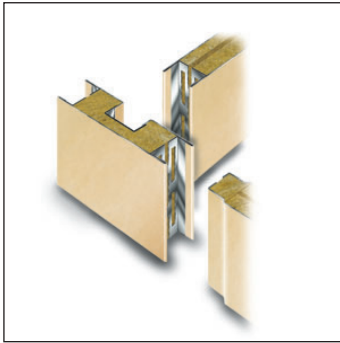

Recess connection for improved flexibility

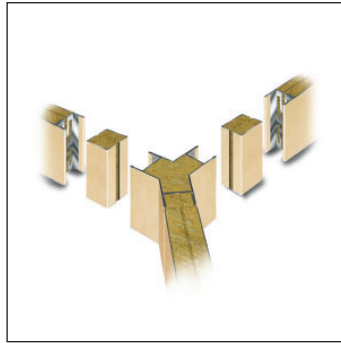

Special solutions available

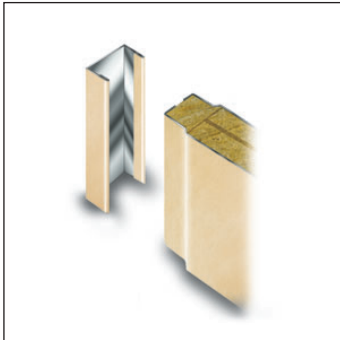

Standard profile for flush finish

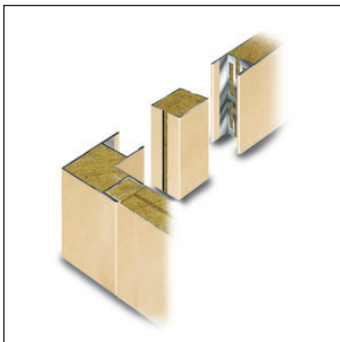

Corner element

**NOTE:**

Norac systems are delivered with a wide variety of connecting elements/profiles to obtain the best solutions.

Corners may also be delivered in stainless steel finish.

WWW.NORAC.NO

